

ITEM NO.	PART NUMBER	Description	QTY.
1	020-6783	BRACKET, MOTOR BASE, FIXED, AC	1
2	050-0411	LABEL, GROUND UL/CSA	3
3	050-1815	LABEL, WARNING, FIRE HAZARD	1
4	110-1510	BOLT, 5/16-18 X 1.75" HHTB	1
5	110-1516	BOLT, CARRIAGE, 5/16-18 X 1.0	4
6	110-1870	NUT, 5/16-18 KEPS	9
7	110-3026	SCREW, 10-24X.50" PPHTCS	18
8	120-0220	WASHER, #10, EXT TOOTH LOCK	3
9	120-3023	WASHER, 5/16 ID, 688 OD	9
10	120-3264	WASHER, SHOULDER, 5/16IDX.15L	4
11	140-3232	CLAMP, WIRE, SADDLE, 1.0"	6
12	140-3234	RIVET, SNAP, .161" HOLE	6
13	140-3240	BUMPER, 3/4x7/16x8-32, RUBBER	1
14	140-3268	GASKET, MOTOR PAD, 1.2x.25x7.0	2
15	140-3270	INSULATOR, MOTOR PAD, MYLAR	4
16	170-0688	BRACKET, RESISTOR	2
17	260-0929	MOTOR, GEAR, 220 VAC	1
18	440-0252	FERRITE, 20.6x6.6x39.4x9.78	1
19	440-0257	FILTER, EMI, 250V, 16A	1
20	470-0406	CIRCUIT BREAKER, 250V, 10A	1
21	715-3170	ASSY, JUMPER, EMI TO BREAKER, 220V	1
22	715-3412	ASSY, CABLE, AC TO MCB	1
23	715-3457	ASSY, CABLE, GROUND WIRE	1
24	715-3484	ASSY, DUST, GUARD, PRO TR	1
25	715-3573	ASSY, MOTOR, AC INDUCTION, 230V	1
26	715-3588	ASSY, RESISTOR, 225W, 1K OHM	1
27	715-3611	ASSY., BLEEDER, AC MOTOR, PRO TR	1
28	715-3619	ASSY, MCB, AC, 220VAC, ACD2U	1
29	715-3672	ASSY, FAN POWER SUPPLY, TR, VLAD	1
30	715-3674	ASSY, CABLE FAN PCB, AC-SYSTEM	1

REVISIONS				
REV.	DATE	DESCRIPTION	ECO#	CHG BY
A	3/7/2007	PRODUCTION RELEASE.	11558	VC
B	05-09-07	P/N: 140-3270 QTY. IS: 4. WAS: 2.	11596	RKL

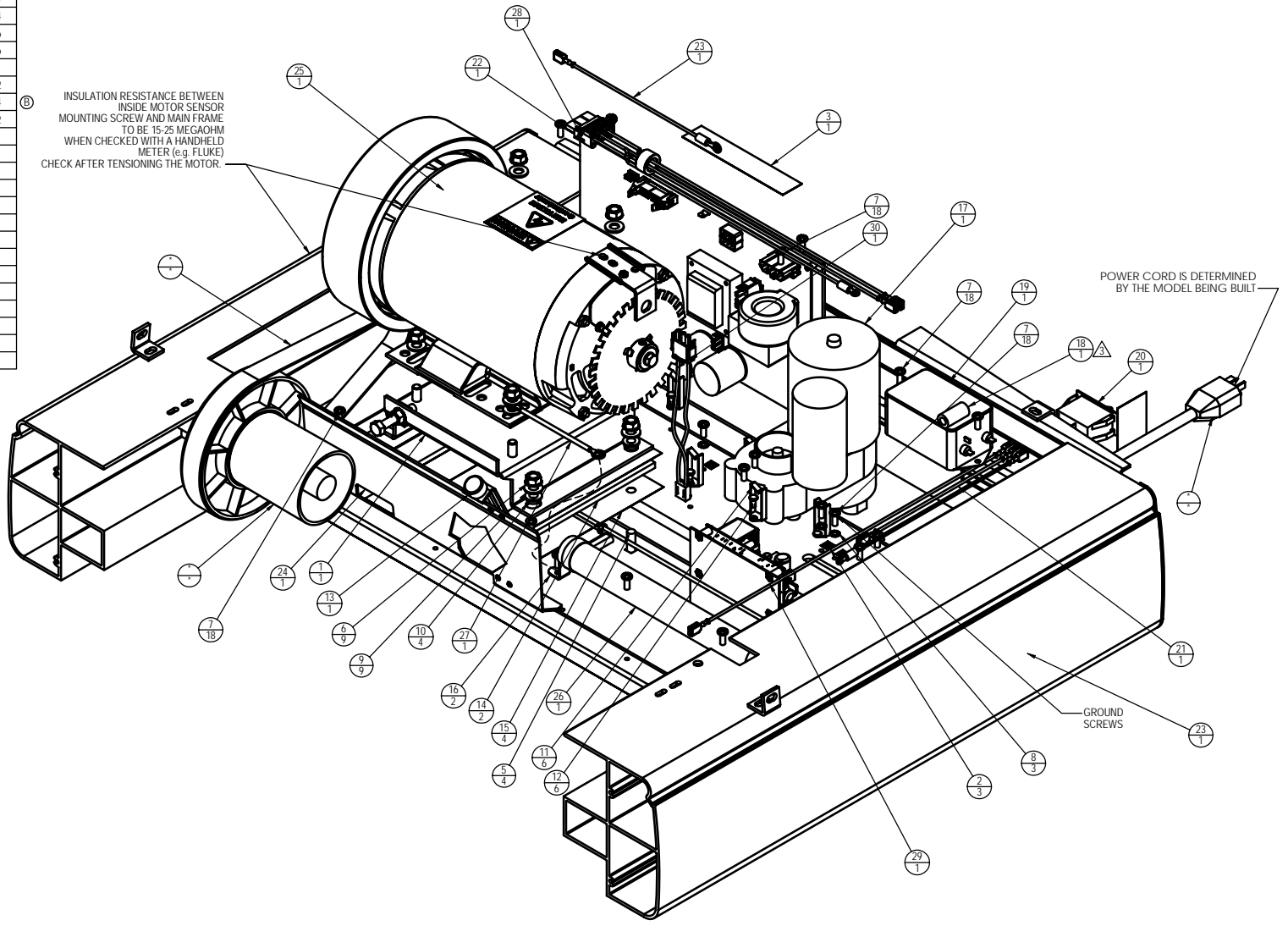

NOTES:
 1. FOR CORRECT WIRE ROUTING REFER TO DOCUMENT #: 620-7462 CABLE ROUTING, PRO TR
 2. ALL COMPONENTS MARKED WITH A STAR (*) ARE FOR REFERENCE ONLY
 3. ATTACH TO THE GROUND WIRE OF THE POWER CORD.

DOCUMENT STATUS:
 RELEASE

NOTICE OF PROPRIETARY INFORMATION
 THIS DOCUMENT SHALL NOT BE REPRODUCED NOR SHALL THE INFORMATION CONTAINED HEREIN BE USED BY OR DISCLOSED TO OTHER EXCEPT AS EXPRESSLY AUTHORIZED BY UNISEN

MATERIAL	SEE BOM	TOLERANCES UNLESS OTHERWISE SPECIFIED	UNISEN, INC. DBA STAR TRAC 14410 Myford Road Irvine CA 92606	
FINISH	NONE	INITIAL	DATE	PART NO
		VC	01-031-07	715-3665
		CHECKED		REV
		APPROVED		B
		U.O.M.	INCH	TITLE
				ASSY, ELECTRICAL KIT, 220V 10A, AC
				SCALE: 2:1 SHEET 1 OF 1 SHEET SIZE: C